

DIN 卡套式管接头

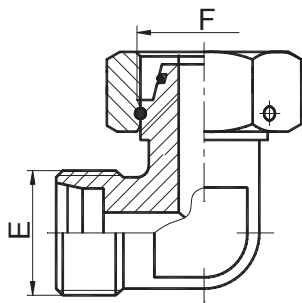

2C9
2D9

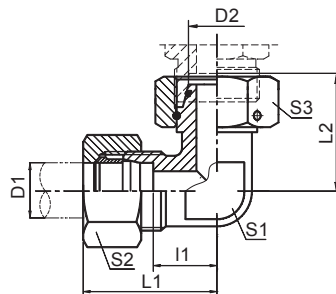

2C9-RN
2D9-RN

外螺纹内螺纹转换接头 90° 弯
REDUCER TUBE ADAPTOR
WITH SWIVEL NUT 90° ELBOW

代号 PART NO.	螺纹 THREAD		管子外径 TUBE O.D.		尺寸 DIMENSIONS						压力等级 MPa
	E	F	D1	D2	l1	L1	L2	S1	S2	S3	
2C9-12	M12X1.5	M12X1.5	6	6	12	27	26	12	14	14	25 轻系列 L
2C9-14	M14X1.5	M14X1.5	8	8	14	29	27.5	12	17	17	
2C9-16	M16X1.5	M16X1.5	10	10	15	30	29	14	19	19	
2C9-18	M18X1.5	M18X1.5	12	12	17	32	29.5	17	22	22	
2C9-22	M22X1.5	M22X1.5	15	15	21	36	32.5	19	27	27	
2C9-26	M26X1.5	M26X1.5	18	18	23.5	40	35.5	24	32	32	
2C9-30	M30X2	M30X2	22	22	27.5	44	38.5	27	36	36	16 轻系列 L
2C9-36	M36X2	M36X2	28	28	30.5	47	41.5	36	41	41	
2C9-45	M45X2	M45X2	35	35	34.5	56	51	41	50	50	
2C9-52	M52X2	M52X2	42	42	40	63	56	50	60	60	
2D9-14	M14X1.5	M14X1.5	6	6	16	31	27	12	17	17	63 重系列 S
2D9-16	M16X1.5	M16X1.5	8	8	17	32	27.5	14	19	19	
2D9-18	M18X1.5	M18X1.5	10	10	17.5	34	30	17	22	22	
2D9-20	M20X1.5	M20X1.5	12	12	21.5	38	31	17	24	24	
2D9-22	M22X1.5	M22X1.5	14	14	22	40	35	19	27	27	
2D9-24	M24X1.5	M24X1.5	16	16	24.5	43	36.5	24	30	30	40 重系列 S
2D9-30	M30X2	M30X2	20	20	26.5	48	44.5	27	36	36	
2D9-36	M36X2	M36X2	25	25	30	54	50	36	46	46	
2D9-42	M42X2	M42X2	30	30	35.5	62	55	41	50	50	
2D9-52	M52X2	M52X2	38	38	41	72	63	50	60	60	31.5 重系列 S

注：如需带卡套及卡套螺母整套订货，则请在代号后加“RN”，如 2C9-30RN。

Note: In case if you are interested to order the adapter in complete set with cutting ring and nut ,it is necessary to insert suffix "RN" after our part no., for example 2C9-30RN.